



## Super Pump® 700

»»» Medium-Head Pump Series

»»» Gammes de pompes à charge moyenne

THE MOST DURABLE VERSION OF THE INDUSTRY'S FAVORITE POOL PUMP  
LE VERSION LA PLUS DURABLE DE LA POMPE DE PISCINE FAVORITE DE L'INDUSTRIE



EXPERT LINE



PREMIUM PRODUCTS  
PRODUITS HAUT DE GAMME



NOT SOLD ONLINE  
EXCLUSIFS



EXTENDED WARRANTIES  
GARANTIES PROLONGÉES

# LONG-LASTING PERFORMANCE FOR POOLS OF ALL SIZES.

## KEY FEATURES

- » **Chemical-resistant Viton seal** offers powerful corrosion protection
- » **Wing nut drain plug** is easy to open and close for winterizing
- » **Exclusive swing-away hand knobs** make for easy strainer cover removal without tools
- » **See-through strainer cover** lets you see when the basket needs cleaning
- » **Extra-large debris basket** provides added leaf-holding capacity for less frequent maintenance



# PERFORMANCE DURABLE POUR LES PISCINES DE TOUTES LES DIMENSIONS.

## CARACTÉRISTIQUES PRINCIPALES

- » **Un joint d'étanchéité en Viton** qui résiste aux produits chimiques et offre une puissante résistance contre la corrosion
- » **Un bouchon de vidage avec écrou papillon** qui est facile à ouvrir et fermer en vue de la préparation pour l'hiver
- » **Des vis de blocage escamotables exclusives** pour facilement enlever le couvercle de la crépine sans avoir recours à des outils
- » **Un couvercle de crépine transparent** pour voir quand le panier doit être nettoyé
- » **Un panier de débris surdimensionné** qui permet de contenir plus de feuilles pour un entretien moins fréquent

## SPECIFICATIONS

MODEL NUMBER	HORSEPOWER		SERVICE FACTOR	PORT SIZE	DIMENSION "A"	WARRANTY
	TOTAL HP	RATED HP				
Standard Efficient Max-Rated Single Speed						
SP2670007X10C	1.10	1	1.10	1½ in	14¼ in	2 years
SP2670010X15C	1.50	1½	1.00	1½ in	15¾ in	2 years

## SUPER PUMP 700 DIMENSIONS (INCHES)

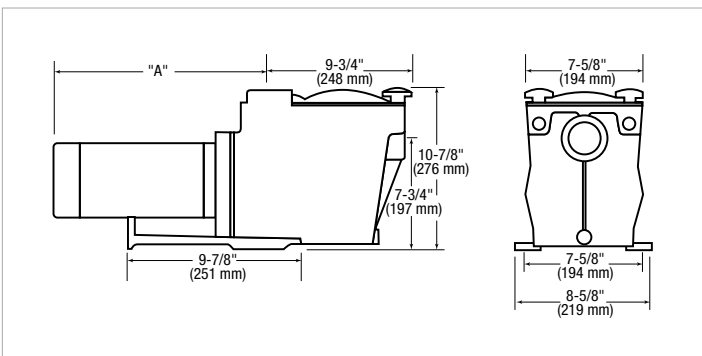

## SUPER PUMP 700 FLOW VS. TOTAL HEAD

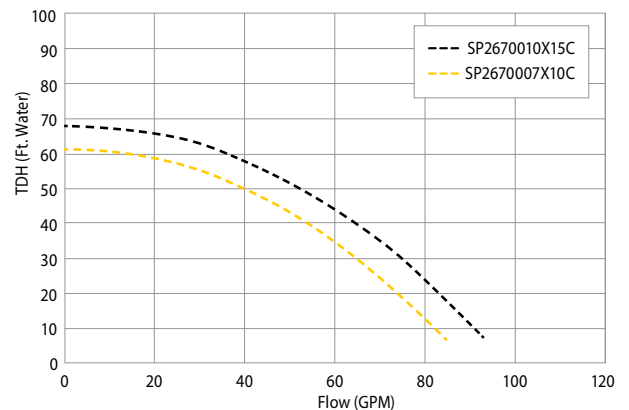

» [haywardpool.ca](http://haywardpool.ca) » 1-888-238-7665

Super Pump 700 pumps are listed by:



Pumps » Filters » Heaters » Cleaners » Sanitization » Automation » Lighting » Water Features » White Goods

Hayward, Hayward & Design, the H logo and Super Pump are registered trademarks of Hayward Industries, Inc. All other trademarks not owned by Hayward are the property of their respective owners. Hayward is not in any way affiliated with or endorsed by those third parties. © 2017 Hayward Industries, Inc.

LITSP70017C

